

**FIGURE-GROUND SEPARATION
BY VISUAL CORTEX**

Stephen Grossberg
Department of Cognitive and Neural Systems
and
Center for Adaptive Systems
Boston University
677 Beacon Street
Boston, MA 02215

February, 1996

Technical Report CAS/CNS-TR-96-010

To appear in
Encyclopedia of Neuroscience
Adelman, G. and Smith, B.H. (Eds).
Amsterdam: Elsevier Science Publishers

1. INTRODUCTION

Figure-ground perception enables us to perceive objects that are distinct from one another and from their scenic background. The remarkable nature of figure-ground perception may be better appreciated when we reflect that percepts of the three-dimensional (3-D) world are derived from two-dimensional (2-D) images projected onto each eye's retina. Percepts of objects often continue to pop-out from their backgrounds even when we view a 2-D picture with a single eye.

Many factors contribute to figure-ground separation, including differences in luminance, color, size, binocular disparity, and motion between a figure and its background. An exposition of all these factors goes beyond the present chapter's more limited goal. Here, perceptual data are summarized that clarify key issues which must be dealt with to understand figure-ground perception, including data about how luminance contrast, binocular disparity, and spatial scale contribute to figure-ground separation in response to both 3-D scenes and 2-D pictures. An outline is then provided of how these data may be explained by a recent model of how the visual cortex works. Although unfamiliar objects can be separated from unfamiliar backgrounds, prior knowledge can also facilitate figure-ground separation. A framework for analysing how unfamiliar figures may be separated, yet how knowledge may modulate or facilitate the separation process, will also be summarized.

2. THE ROLE OF PERSPECTIVE

Since the Renaissance, perspective has been used in drawings and paintings to make figures appear to pop-out from their backgrounds. Typically, a large foreground figure (say of a person) in front of small background figures (say of trees, houses, and hills) makes the foreground figure appear nearby and the background figures appear farther away. A 2-D picture can hereby generate a 3-D percept. This type of observation supports the maxim that "large size scales signal near objects." As with many other properties of visual perception, this maxim is not always true, as will be noted below.

Whatever their cause, 3-D figure-ground percepts derived from 2-D pictures show that the points and lines of Euclidian geometry and the surface elements and normals of Gaussian geometry are insufficient to explain figure-ground separation. New geometrical ideas explain how a 2-D picture can generate a 3-D percept. Points and lines are generalized to emergent boundary segmentations, and surface elements and normals are replaced by the filling-in of surface properties. What these segmentation and surface processes are and how they work is indicated below.

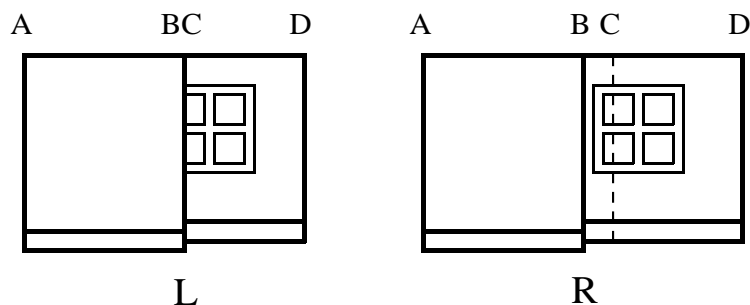

Figure 1.A DaVinci stereopsis display. [Figure reprinted with permission from Grossberg, 1994.]

3. THE SIZE-DISPARIETY CORRELATION

Image size alone is not a reliable cue to a figure's depth. In particular, a nearby small object and a far away large object may both subtend the same "size" on the retina. Another cue to depth is the different relative positions, or binocular disparity, with which an object is registered on an observer's two retinas. Under many viewing conditions, farther objects generate a smaller binocular disparity than nearer objects.

Combining information about size and disparity is much more informative. For example, two objects may generate identical retinal image sizes, but the one that generates a larger disparity under appropriate viewing conditions will be closer, and therefore smaller. This linkage between size and disparity is called the size-disparity correlation. It has often been proposed that larger receptive fields, or spatial scales, preferentially represent the size-disparity correlations of nearer, and thus larger and binocularly more disparate, objects. Such an implementation of size-disparity correlation is not sufficient, however, as the next examples show.

4. DA VINCI STEREOPSIS

When we view a farther surface that is partly occluded by a nearer surface, one eye typically registers more of the farther surface than the other eye does. Our conscious percept of the farther surface is often derived from the view of the eye that registers more of this surface. For example, under the viewing conditions depicted in Figure 1, observers see surface BC at the same depth as surface CD, even though surface BC is registered by only the right eye. Thus BC is part of the same "figure" as CD, even though only CD benefits from binocular disparity cues. This perceptual situation is often called DaVinci stereopsis.

March 12, 1996

The perceptual properties that subserve this percept will now be illustrated under simpler stimulus conditions.

5. BINOCULAR FUSION AND ALLELOTROPIA

Each eye views the world from a different position in the head. The same material point on an object is therefore registered at a different location on the two retinas, except for that object region which is foveally fixated by both eyes. To binocularly fuse such a disparate pair of monocular images, the two images must be deformed into one percept. This fusion property is called *allelotropia*. For example, when a pattern EF G is viewed through one eye and a pattern E FG is viewed through the other eye, the letter F can be seen in depth at a position halfway between E and G. Thus the process of binocular fusion deforms the two monocular appearances of F into one binocular percept of F whose spatial position differs from either monocular position of F with respect to E and G.

The amount of deformation needed to achieve binocular fusion of a 3-D scene depends upon how far away each object is with respect to an observer's retinas. Thus different parts of the left eye and right eye images are deformed by different amounts to generate a single binocular percept of the world. For example, the vertical boundaries of regions AB and CD in the left eye and right eye images of Figure 1 need to be deformed by different amounts. In particular, the retinal images of objects at optical infinity have zero disparity on the two retinas, and the disparities on the two retinas of corresponding object points tend to increase as an object approaches the observer. On the other hand, when both eyes focus on a single point on a planar surface viewed in depth, the fixation point is a point of zero disparity. Points of the surface that are registered by the retinas further from the fixation point generate larger binocular disparities. Why do planar percepts not recede towards optical infinity at the fixation point and curve towards the observer at the periphery of the visual field? Why does the plane not become distorted in a new way every time our eyes fixate on a different point on its surface? In addition, a "zero disparity" condition also occurs under monocular viewing conditions, as in detecting region BC of Figure 1. How does the monocularly viewed region BC inherit the depth of the binocularly viewed region CD, rather than looking very far away?

6. FILLING-IN OF SURFACE PROPERTIES

Both the absence of "holes" in space due to boundary fusion and the inheritance by BC of the depth CD may be explained by a diffusive filling-in process that selectively completes a BC surface representation at a depth corresponding to that of region CD. In other words, the process that fills-in the surface depth of CD in response to its binocular boundaries keeps

flowing until it also fills-in BC.

7. BOUNDARY SEGMENTATION

The surface filling-in process is activated and contained by boundary segmentations. Some boundaries are derived from binocularly viewed parts of a scene, others from monocularly viewed parts. In Figure 1, binocular fusion of the AB boundaries and the CD boundaries registers different disparities and amounts of allelotropia. The monocularly viewed boundaries in region BC do not register any binocular disparity. Nor do the horizontal image boundaries. Thus at least three ways exist for image boundaries to be registered with zero, or near-zero, disparity: as an occluded region during DaVinci stereopsis, as a monocularly viewed image, or as a horizontal boundary during either monocular or binocular viewing. Monocular and near-zero disparity cells are known to be separately processed by visual cortex. Grossberg (1994) suggested that monocular and near-zero disparity boundaries are processed in a separate pool of cortical cells for the following reasons.

8. MONOCULAR AND NEAR-ZERO DISPARITY CELL POOLS

The monocularly viewed vertical and horizontal boundaries in region BC need to be joined with the binocularly fused, large disparity vertical boundaries and horizontal near-zero disparity boundaries in region CD to form the window frame in Figure 1. Disparity-sensitive cortical cells are tuned to a limited range of disparities. These cells are segregated into separate cell pools that are organized to correspond to different relative depths of an observed image feature. Suppose that monocular or near-zero disparity cell outputs are combined with the spatially organized activations of all the non-zero disparity cell pools to create a more complete boundary representation (Figure 2a). In response to the scene in Figure 1, BC boundaries are added to CD boundaries at those scales and disparities that are capable of computing binocularly fused CD boundaries. These composite BCD boundaries enclose *connected* regions, such as the connected window frame in the right eye image of Figure 1, if the following problem can be solved.

9. BOUNDARY COMPLETION

Due to allelotropia, the binocularly fused boundaries within region CD may be positionally displaced relative to the monocularly viewed boundaries within region BC. As a result, gaps may occur between the locations of cells in the visual cortex that represent binocular and monocular boundaries. When regions contain oblique contours, the binocular and monocular responses of cortical cells may be both orientationally and positionally displaced. These gaps and misalignments need to be corrected by a boundary completion

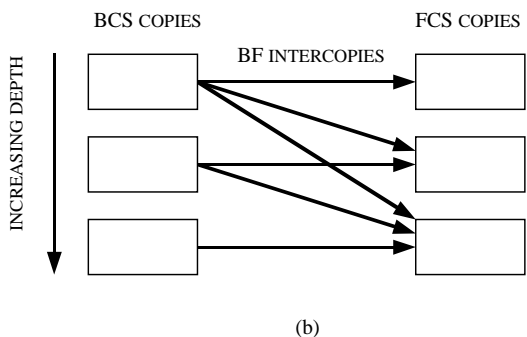
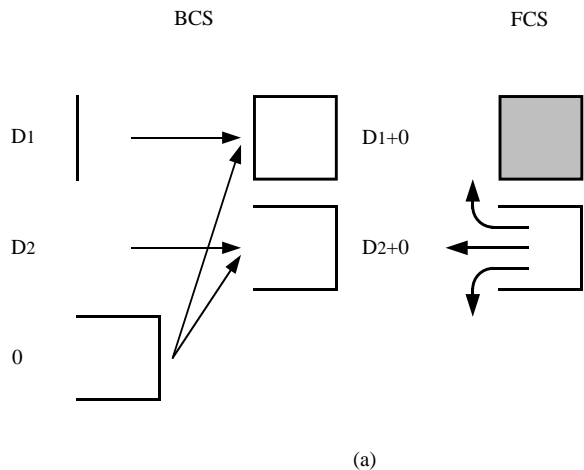

Figure 2. (a) Near-zero disparity and monocular boundaries are added to boundaries of all the selective pools of non-zero disparity cells (with disparities D_1 and D_2). Only regions enclosed by connected boundaries can fill-in. Other regions dissipate activity through uncontrolled diffusion. (b) Multiple FCS copies exist corresponding to the BCS copies that code different ranges of relative depth from an observer. Each FCS copy contains a complete set of Filling-In Domains, or FIDOs that correspond to the opponent colors (red, green), (blue, yellow), and (black, white). Near boundaries add to far boundaries in the FCS copies to prevent filling-in from occurring behind opaque surfaces. [Figure reprinted with permission from Grossberg, 1994.]

process. Boundary completion is capable of generating an emergent boundary segmentation which realigns and connects the boundaries that join regions BC and CD. These completed boundaries completely enclose the window frame in Figure 1.

10. CAPTURE AND FILLING-IN OF 3-D SURFACE PROPERTIES

The connected boundaries within region BCD form a sparse and discontinuous representation of the scene. How are the scene's continuous surface properties generated to form scenic figures with brightnesses, colors, and surface depths? Suppose that only those boundaries which enclose *connected* regions in BCD, can trigger and contain filling-in of surface properties for the regions that comprise the final visible 3-D percept (Figure 2a). Multiple filling-in domains, or FIDOs, are controlled by boundaries that are sensitive to a restricted range of binocular disparities (Figure 2b). A brightness or color input signal is broadcast to all the FIDOs that code its color. Filling-in is triggered in only those FIDOs where color signals (called FCS signals) and boundary signals (called BCS signals; see Section 14) spatially coincide. These 3-D boundaries hereby "capture" the monocular surface color signals for their FIDO. Filling-in diffuses featural activity across a FIDO until it hits a boundary barrier. The activity dissipates unless a connected boundary can contain it. Because (as explained below) region BCD in Figure 1 contains a connected boundary within the FIDO corresponding to the binocularly fused boundaries of region CD, its surface representation combines position, size, depth, orientation, brightness, and color properties that are consistent with its inducing BCS and FCS signals.

11. THE ASYMMETRY BETWEEN NEAR AND FAR

How does the filling-in of surface BC at the depth of CD stop at boundary B? Boundary B is binocularly fused at a disparity corresponding to a nearer surface than are the boundaries of region CD. Without further processing, boundary B could not form a connected boundary around region BD, or prevent filling-in of region AB within the FIDO whose depth corresponds to region CD. Filling-in of a possibly different surface color would also occur within the FIDO whose depth corresponds to boundaries A and B of region AB. If both filling-in events could occur, region AB would appear transparent. What prevents all figures from looking transparent?

This will not happen if the boundaries of closer objects are added to the boundaries of further objects in the FIDOs (Figure 2b), so that near and far scenic data are processed asymmetrically. Then the BCS boundary is connected and filling-in from region BD does not flow behind region AB. This restriction upon surface filling-in does not prevent *boundaries* from being completed behind an occluding region. Then pathways from boundary representations to the object recognition system (Figure 3) enable partially occluded figures to be recognized via their completed boundaries, even if visible surface properties are not filled-in behind the occluding object.

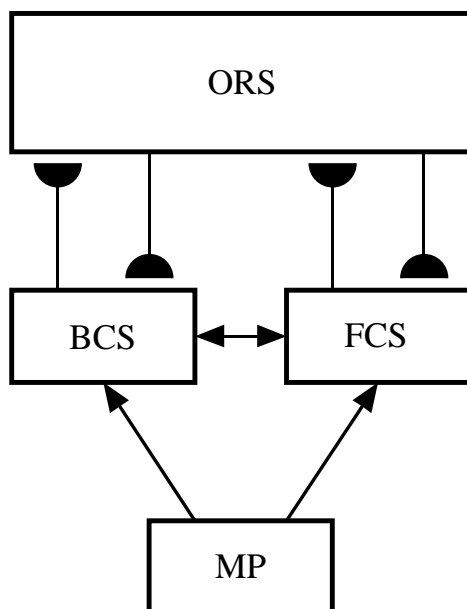

Figure 3. Completed boundaries within the Boundary Contour System (BCS) can be recognized within the Object Recognition System (ORS) via direct BCS \rightarrow ORS interactions whether or not they are seen in the Feature Contour System (FCS) by separating two regions with different filled-in brightnesses or colors. [Figure reprinted with permission from Grossberg, 1994.]

These properties of DaVinci stereopsis illustrate how the multiple spatial scales that are used for disparity-selective early visual filtering may interact with later boundary segmentation and surface filling-in processes to bind visual features into surface representations of figure and ground.

12. THE WEISSTEIN EFFECT

The Weisstein effect clarifies how depthful figure-ground percepts can occur in response to pictures that are constructed from multiple spatial scales or spatial frequencies. As noted above, large size scales, or low spatial frequencies, often seem to selectively process near objects, whereas high spatial frequencies selectively process far objects. In contrast to this property, if regions filled with relatively higher spatial frequency sinusoidal gratings are adjacent to regions containing relatively lower spatial frequency gratings, then the regions with the higher frequency usually appear closer in depth than those containing the lower frequency. They studied a variant of the Rubens faces/vase figure for which a temporally

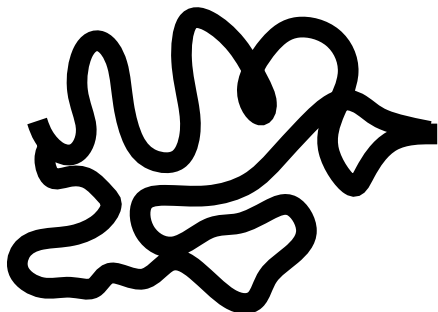

Figure 4. Role of occluding region in recognition of occluded letters: (a) Upper case “B” letters partially hidden by a black snake-like occluder; (b) same, except occluder is white, and therefore merges with the remainder of the white background. Although the exposed portions of the letters are identical in (a) and (b), they are much better recognized in (a). [Reprinted with permission from Nakayama, Shimojo, and Silverman, 1989.]

bistable percept is typically perceived. At one instant, two faces pop-out as figures. At the next instant, a vase pops-out between the faces as they recede into the background. With a higher spatial frequency sinusoid placed within the faces than the vase, the faces are perceived as figures most of the time, and conversely. The Weisstein effect shows that whether a spatial frequency difference signals “near” or “far” depends upon how the image is segmented into boundaries and surfaces, not merely upon a spatial frequency difference *per se*.

13. OCCLUDED AND OCCLUDING FIGURES IN PICTURE PERCEPTS

The spatial organization and relative luminance of occluding and occluded objects influences figure-ground perception during inspection of 2-D pictures as well as 3-D scenes. Comparing Figures 4a and 4b shows that the occluding black sinewy shape in front of the occluded B’s is needed to readily recognize them as B’s.

How does a 2-D image create a 3-D percept of occluding figures in front of occluded figures, as in Figure 4a? How are the gray fragments easily recognized in Figure 4a as occluded B shapes but not in Figure 4b, even though they are equally well seen in both? The 3-D representation in Figure 4a enables the occluded boundaries of the B shapes to be

completed for purposes of recognition, even though the occluded surfaces are not seen in either figure. How does this happen?

Suppose that the boundaries which are shared by the gray B shapes and the black occluder are assigned to the occluder and detached from the remaining B boundaries. Suppose also that these shared boundaries, along with the other occluder boundaries, are used to generate a boundary segmentation and filled-in surface representation of the black occluder in a FIDO “in front of” the FIDO on which the B fragments fill-in. These occluder boundaries are also reattached to the B boundaries at a later processing stage, as in DaVinci stereopsis, to keep the gray from flowing behind the black (Figure 2b).

14. OCCLUDED BOUNDARY COMPLETION AND AMODAL RECOGNITION

Given that the shared boundaries between occluder and B shapes are somehow removed from the B shapes, how does an observer recognize the incomplete B figures? Once the obstructing occluder boundaries are removed, a boundary completion process generates illusory contours between the (approximately) colinear line ends of the incomplete B figures. If, however, illusory contours complete the B shapes and thereby enhance their *recognition*, why do we not *see* these illusory boundaries?

Figure 3 schematizes part of the model’s answer. A boundary that is completed within the segmentation system (which is called the Boundary Contour System, or BCS) does not generate visible contrasts within the BCS. In this sense, *all boundaries are invisible*. Visibility is a property of the surface filling-in system (the Feature Contour System, or FCS). The completed BCS boundary can directly activate the visual Object Recognition System (ORS) whether or not it is visible within the FCS. Neurophysiological data suggest that the ORS includes the inferotemporal cortex whereas the FCS visible surface representation includes area V4 of the extrastriate cortex. A boundary may thus be completed within the BCS, and thereby improve pattern recognition by the ORS, without necessarily generating a visible brightness or color difference within the FCS. In the classical literature, such boundaries were said to be *amodally* completed, but the relationship between amodal completion, modal completion, and filling-in was not specified.

15. AN EXPLANATION OF BREGMAN-KANIZSA FIGURE-GROUND SEPARATION

A sketch of how the BCS-FCS interactions explain Bregman-Kanizsa figure-ground pop-out will now be given. The white/black contrast of the occluding black band with respect to the white background in Figure 5a is greater than the white/gray and gray/black contrasts

caused by the occluded B shapes. As a result, oriented simple cells in the BCS are more active at the white/black contrasts than at the white/gray and gray/black contrasts (Figure 5b). The simple cells activate complex cells during binocular viewing for the picture in 3-D space (Figure 5c). Since the image is viewed by both eyes at a distance, it generates a binocular disparity at each image point. Let D_1 represent the set of all disparities that correspond to the planar image surface when it is binocularly viewed by an observer.

In Figure 5c, the larger receptive field size represents the largest complex cell scale that can binocularly fuse disparity D_1 . Complex cells at the same position and scale then compete across disparities. The active larger scale cells win the competition. Thus no complex cells fire at the smaller disparity D_2 of the larger scale. Smaller scale cells cannot binocularly fuse as wide a range of disparities as larger scales, due to the size-disparity correlation. The smaller scale in Figure 5c cannot fuse D_1 but it can fuse the smaller disparity D_2 . Because disparity cells are coarsely coded before competition occurs, the smaller scale complex cells that are tuned to disparity D_2 can respond to the image contours. Since there are no smaller scale complex cells tuned to D_1 , no smaller scale competition occurs from disparity D_1 to D_2 . Thus Figure 5c results from three properties: (a) a size-disparity correlation for binocular fusion; (b) coarse-coded non-zero disparity computations at binocular complex cells; (c) competitive sharpening of disparity-sensitive complex cell responses within each scale, with larger fusable disparities winning over smaller ones.

Figure 5d shows that holes in the boundary, called end gaps, are formed at the B boundaries as a result of the boundary completion circuit that completes illusory boundaries, among other boundary segmentations. These end gaps are due to spatial competition that is activated by the cooperative process that forms the occluder boundaries in response to the high-contrast occluder edges.

In Figure 5e, binocular BCS boundaries and monocular FCS signals input to monocular FIDOs. The binocular BCS boundaries capture the monocular FCS signals that are consistent with them. All other monocular FCS signals are suppressed. The selected FCS signals fill-in their respective monocular FIDOs. The filling-in signals cross end gaps and dissipate across space unless they are contained by other nearby boundaries. Only the occluder boundaries can contain the filling-in process within the monocular FIDOs during the first phase of the processing cycle.

Monocular FIDO outputs are derived from a competitive network that responds to spatial contrast. Each filled-in FIDO region that is surrounded by a connected boundary hereby generates contour-sensitive output signals (Figures 5f). Output signals are generated only at the edges of the black occluder. These FCS output signals activate parallel pathways

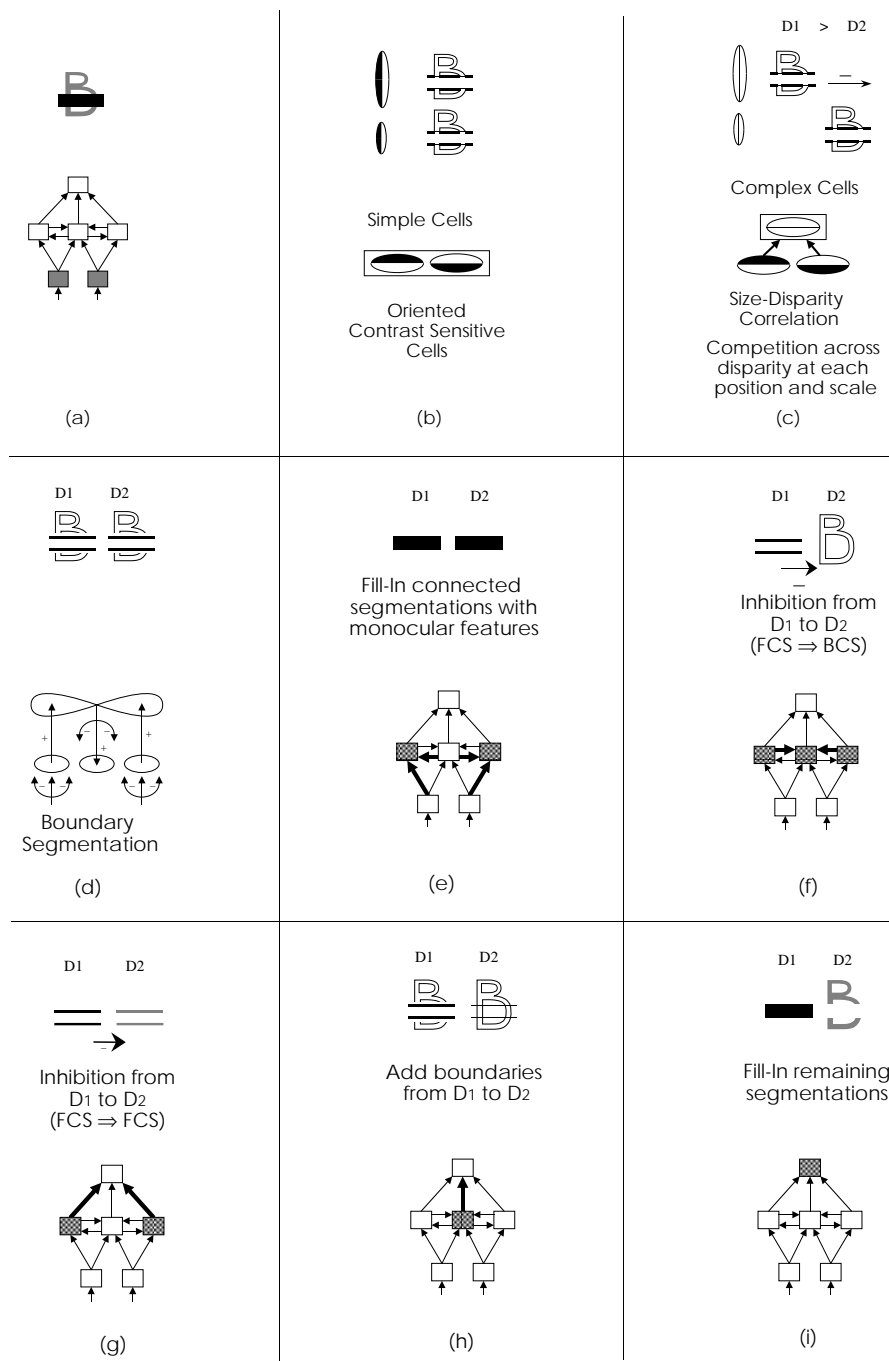

Figure 5. Bregman-Kanizsa figure-ground separation: (a) Image; (b) Monocular simple cell activations in the BCS; (c) Complex cells at a given position and size scale compete across disparity, here disparities D_1 and D_2 , with the larger disparity typically winning; (d) Boundaries after bottom-up and top-down orientational and spatial competition generate ends gaps at weaker edge terminators; (e) Filling-in of surfaces at the monocular filling-in domains (FIDOS) is effective only if each surface is surrounded by a connected boundary; (f) Contour-sensitive FCS output signals from these filled-in connected surfaces strengthen BCS boundaries at the same position and depth D_1 , but inhibit boundaries at the same positions within the BCS copies that correspond to farther depths such as D_2 , thereby freeing the boundaries of the B fragments to be completed; (g) Contour-sensitive FCS output signals from the filled-in connected surfaces of a monocular FIDO inhibit the filling-in generators of binocular FIDOS that correspond to farther depths; (h) BCS boundaries of nearer depths are added at the FCS binocular FIDOS that correspond to farther depths; (i) Filling-in of binocular FIDOS that are surrounded by connected boundaries using monocular FCS signals that are not suppressed by the cross-disparity inhibition of (h).

that influence both the BCS and the FCS. The FCS \rightarrow BCS feedback signals enhance the boundaries at their own depth but inhibit the boundaries at the same positions and farther depths. In particular, the occluder boundaries are inhibited at disparity D_2 . The incomplete B boundaries at disparity D_2 can then be colinearly completed (Figure 5f). These completed B boundaries generate BCS \rightarrow ORS signals (Figure 3) whereby they are amodally recognized. Thus a completed letter B can be recognized at the ORS, even if only its unoccluded surfaces are seen at the FCS.

Why is the letter B not completely seen at the FCS? Contour-sensitive FCS \rightarrow FCS output signals are binocularly matched at the binocular FIDOs of the FCS (Figure 5g). This excitatory binocular interaction positionally matches monocular signals that code the same depth and color. In addition, FCS \rightarrow FCS signals inhibit all the FCS signals at their position which correspond to farther depths. Thus a surface that fills-in at a nearer depth cannot also fill-in at a farther depth unless suitably configured end gaps exist that generate a percept of transparency. The surviving matched signals trigger filling-in of the visible representation at the binocular FIDOs.

FCS signals from farther depths but different positions cannot fill-in behind a nearer occluding surface because boundaries at each depth are added at the binocular FIDOs that represent larger depths (Figure 2b). As a result, complete boundaries of both the occluder and the completed B shapes exist at the farther depth (Figure 5h). These boundaries obstruct filling-in behind the occluder.

These FCS and BCS inputs to the binocular FIDOs generate the binocular filling-in events in Figure 5i. The B surface is filled-in at disparity D_2 only where it is not occluded. The occluding surface is not filled-in at all at disparity D_2 . The occluding surface is filled-in at disparity D_1 because its FCS signals are contiguous to boundary signals that completely enclose them in connected regions. Because $D_1 > D_2$, the black occluding surface appears to be closer than the gray occluded B surface. The black occluder is the figure that pops-out from its background. The completed boundary segmentations can be recognized, even though only their unoccluded surface representation can be seen.

16. CONCLUDING REMARKS

The above experimental data and theoretical concepts suggest that figure-ground separation in particular, and biological vision in general, uses principles and mechanisms that are very different from those described in classical geometries and computer vision algorithms. These new ideas, which have been used to explain many data about figure-ground perception (Grossberg, 1994), are naturally expressed using a biologically neural network model

March 12, 1996

in which the complementary properties of emergent boundary segmentations and filled-in surface representations are interactively combined.

ACKNOWLEDGEMENTS

Professor Stephen Grossberg was supported in part by the Office of Naval Research (ONR N00014-95-1-0409 and ONR N00014-95-1-0657).

Thanks to Diana J. Meyers for her valuable assistance in the preparation of the manuscript.

REFERENCES

- Bregman, A.L., 1981,. Asking the “what for” question in auditory perception. In M. Kubovy and J.R. Pomerantz (Eds.), **Perceptual organization**. Hillsdale, NJ: Erlbaum Associates, 99–118.
- Desimone, R., Schein, S.J., Moran, J., and Ungerleider, L.G., 1985, Contour, color, and shape analysis beyond the striate cortex. *Vision Research*, **25**, 441–452.
- DeYoe, E.A. and Van Essen, D.C., 1988, Concurrent processing streams in monkey visual cortex. *Trends in Neurosciences*, **11**, 219–226.
- Gove, A., Grossberg, S. and Mingolla, E. (1995). Brightness perception, illusory contours, and corticogeniculate feedback. *Visual Neuroscience*, **12**, 1027–1052.
- Grossberg, S., 1994, 3-D vision and figure-ground separation by visual cortex. *Perception and Psychophysics*, **55**, 48–120.
- Grossberg, S. and Todorović, D., 1988, Neural dynamics of 1-D and 2-D brightness perception: A unified model of classical and recent phenomena. *Perception and Psychophysics*, **43**, 241–277.
- Julesz, B. and Schumer, R.A., 1981, Early visual perception. *Annual Review of Psychology*, **32**, 572–627.
- Kanizsa, G., 1979, **Organization in vision: Essays in Gestalt perception**. New York: Praeger Press.
- Klymenko, V. and Weisstein, N., 1986, Spatial frequency differences can determine figure-ground organization. *Journal of Experimental Psychology: Human Perception and Performance*, **12**, 324–330.
- Mishkin, M. and Appenzeller, T., 1987, The anatomy of memory. *Scientific American*, **256**, 80–89.
- Nakayama, K. and Shimojo, S., 1990, DaVinci stereopsis: Depth and subjective occluding contours from unpaired image points. *Vision Research*, **30**, 1811–1825.
- Nakayama, K., Shimojo, S., and Ramachandran, V.S., 1990, Transparency: Relation to depth, subjective contours, luminance, and neon color spreading. *Perception*, **19**, 497–513.
- Poggio, G.F. and Talbot, W.H., 1981, Mechanism of static and dynamic stereopsis in foveal cortex of the rhesus monkey. *Journal of Physiology*, **315**, 469–492.
- Watanabe, T. and Cavanagh, P., 1992, Depth capture and transparency of regions bounded by illusory and chromatic contours. *Vision Research*, **32**, 527–532.

March 12, 1996

Zeki, S., 1983, Colour coding in the cerebral cortex: The reaction of cells in monkey visual cortex to wavelengths and colours. *Neuroscience*. **9**, 741-765.