



RECORD SETTINGS

format: HQ 1920/23.98P (23.976) color: 4:2:0 (internal SxS)
shutter: 180° optional S-Log
TC: NDF file: XDCAM EX

QUICK SET-UP

SWITCH/BUTTON SET

① SET shutter SHUTTER ON
② SELECT ISO GAIN L 400 · M 800 · H 1600
③ SELECT color temp. TUNGSTEN PRST 3200K
④ DAYLIGHT set ATW ③ to PRST
set (button) 5600K

MENU

- RESET to factory
 - OTHERS → All Reset → Execute
- SET shutter
 - CAMERA → Shutter → Mode: Angle
- SET format
 - OTHERS → System → Format: HQ 1920/23.98P
- SET LCD display
 - LCD/VF SET → Marker → Aspect Marker: Line
 - Aspect Select: 1.85:1
 - Gain Setting: ISO
 - Display On/Off
- FORMAT media
 - OTHERS → Format Media → Media(A)
 - Media(B)

- ▶ CREATE Disk Image of SxS card
- ▶ do not force SxS card

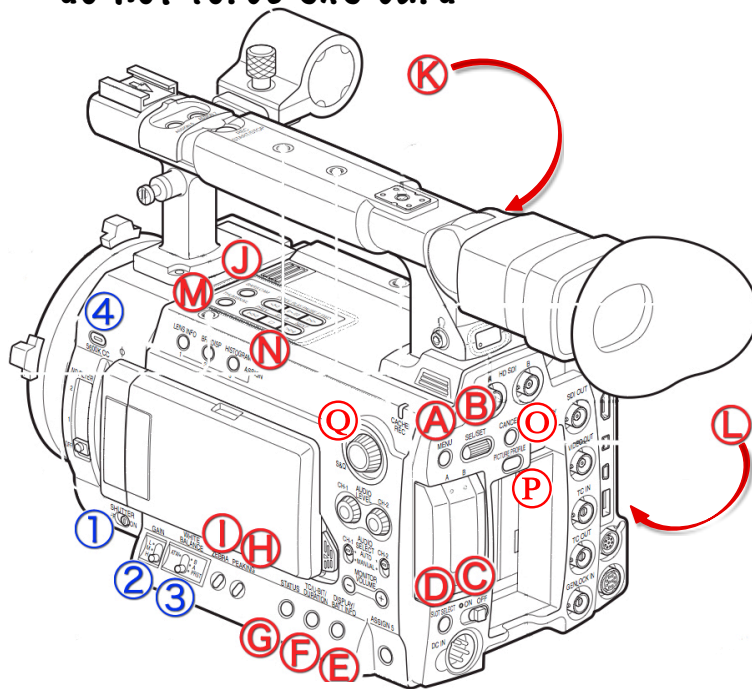

ADDITIONAL FUNCTIONS

S&Q knob to Jog dial (menu navigate)

▶ press/hold CANCEL Ⓞ ▶ press S&Q knob Ⓞ

Shutter

CAMERA → Shutter → Mode: Angle
→ Shutter Angle: 216°·180°·172.8°·150°·144°·90°
86.4°·72°·45°·22.5°·11.25°

Frame Rate (slow & quick motion)

CAMERA → S&Q Motion → Format: HQ 1920/23.98
(S&Q NOT set to jog dial) ▶ press S&Q Ⓞ ▶ Execute (blue outline illumin.)

LCD display

LCD/VF SET → Peaking (focus assist) → Color: White·Red·Yellow·Blue
→ Level: High·Mid·Low
→ Marker → Setting: On
→ Safety Zone: Off
→ Center Marker: Off
→ Aspect Marker: Line
→ Aspect Select: 2.35:1·1.85:1·1.66:1·1.59:1·1.5:1·1.4:1·1.3:1·1.25:1
→ Display On/Off → AudioLevelMeter: Off
→ TLCS Mode: Off (Total Level Control System)

Define Clip Name

OTHERS → Clip → Auto Naming: Title
→ Title Prefix: user defined ie. 1A_
→ Number Set: user defined ie. 0001

Timecode / User Bit

TC/UB SET → Timecode → Mode: Preset
→ Run: Rec Run vs Free Run
→ Setting: user defined ie. military time of day
→ User Bit → Mode vs. Fix
→ Setting: user defined ie. date
→ TC Format → NDF (set from format type)

S-Log

PICTURE PROFILE Ⓟ → SEL → PP: STANDARD
→ SET → Profile Name user defined ie. S-Log
→ Gamma → Select: S-Log

F3 BUTTON/SWITCH

① SHUTTER	(switch)	OFF ON	exposure time (motion blur)
② GAIN	(switch)	L M H	light sensitivity (signal gain) L(400iso)·M(800iso)·L(1600iso)
③ WHITE BALANCE	(switch)	PRST A B	PRST(3200K)·A(user)·B(user)
④ 5600K CC	(toggle)	OFF ON	daylight color correction (when WB switch PRST)
A MENU	(toggle)	OFF ON	
B SEL/SET	(toggle)	scroll set	navigate menu
C POWER	(switch)	ON OFF	
D SLOT SELECT	(toggle)	(A) (B)	
E DISPLAY/BATT INFO	(toggle)	show hide	
F TC/UB/DURATION	(toggle)	TC UB	
G STATUS	(toggle)	show hide	
H PEAKING	(toggle)	ON OFF	image contour (focus assist)
I ZEBRA	(toggle)	ON OFF	luminance (exposure assist)
J BARS/CAM	(toggle)	Camera Color Bars	
K EXPAND FOCUS	(toggle)	ON OFF	digital zoom (focus assist)
L REC START/STOP	(toggle)	record	
M THUMBNAIL	(enter)	clip view	playback recorded clip files
N STOP	(exit)	clip view	
Ⓞ CANCEL			
P PICTURE PROFILE			
Ⓞ S&Q	(adjust)	frame rate	slow & quick motion

TIME CODE JAM

- connect cable → F3 TC Out (BNC) → 702T TC IN (5pin Lemo)
- set F3 TC → TC/UB SET → Timecode → Run: Free Run
- set 702T TC → menu 42: TimeCode Mode: FreeRun-JamOnce
→ menu 45: TimeCode: JamRXTX [ENTER]